

# Smart Valve

Pressure Independent Flow Control

**ALLENGRA**  
Flow meters



## Overview

- Flow Control Valve with **Ceramic Disc Technology**
- Integrated **Ultrasonic Flow Sensor**
- Integrated **Temperature and Pressure Sensor**
- Built-in **control algorithm**
- For Water, Water+Detergent *and many others*
- Accuracy  $\pm 2\%$  of measured value
- Blockage detection & release routine
- Adapters for various hydraulic connection types
- Robust and durable

## Operating conditions

Media	Water, Water+Detergent <i>and many others</i>
Operating temperature	0 – 110 °C
Over temperature	110 °C < 5 min
Storage temperature	-40 – +80 °C
Operating pressure	0 – 10 bar
Burst pressure	16 bar
IP code	IP54
Humidity	< 80 % RH
Lifetime	> 8 years

## Compliance

CE Marking	Compliant to all applicable EU Directives (EMC, RoHS, PED)
REACH Regulation	Compliant
Drinking Water	All materials compliant to the German FEA guidelines (UBA BWGL)

## Materials

Wetted parts	PPS, EPDM, Ceramic, Stainless Steel
Non-wetted parts	POM, Brass

## Features

Pressure Independent Flow Control	Maintains <b>constant flow</b> despite pressure fluctuations or hydraulic system changes.
Blockage Detection and Release Routines	Detects valve blockages and has built-in mechanisms to unblock them.

# Smart Valve

Pressure Independent Flow Control

## Flow Regulation

Valve Technology Ceramic Discs

Kvs 2.25 m<sup>3</sup>/h

Valve Characteristics

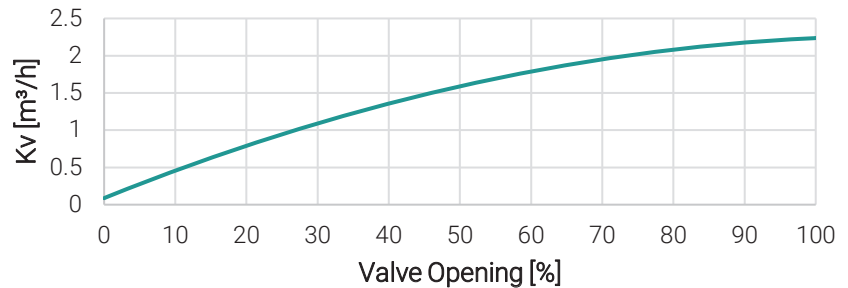

Resolution 1 L/h

Hysteresis 3 L/h + 3% of measured value

Cycles *open - close* > 5.000.000

Opening/Closing Time < 3 s / < 5 s

## Flow Measurement

Measurement technology Ultrasonic

Measurement range 5 – 2500 l/h 0.08 – 42 l/min

Accuracy ±2 % of measured value \*

Repeatability ±1 % of measured value

Response time < 0.2 s

Accuracy funnel

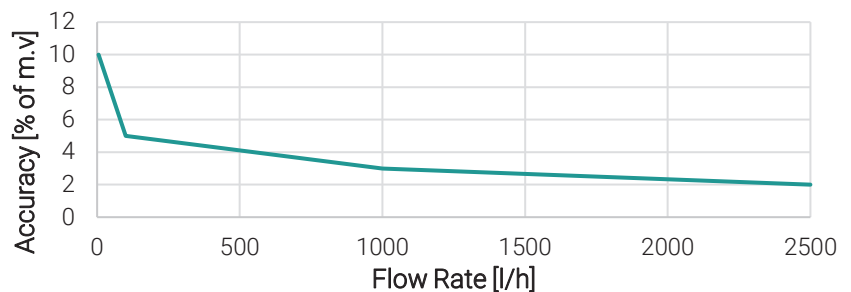

\* Accuracy specification per accuracy funnel, assuming turbulence-free flow conditions (refer to [installation notes](#)).

## Internal Temperature Measurement

Measurement element PT1000

Measurement range 0 - 90 °C

Accuracy ±1 K

Repeatability ± 0.15 K

Response time T70 3 s (T70) 5 s (T95)

## Pressure Measurement

Measurement element Ceramic pressure sensor

	Standard	Optional
Measurement range	0 – 1 bar	0 – 6 bar

Accuracy 1 % of measured value

Repeatability 0.5 % of measured value

Response time < 0.2 s

# Smart Valve

Pressure Independent Flow Control

## Electrical data

Power Supply	19-50 VDC
Power consumption	< 10 W
Electrical interface:	Cable 6 x AWG20 (Length 250mm) Universal MATE-N-LOK, 6-pin, male, waterproof

## Electrical interface

Cable length	250 mm
--------------	--------

	Standard	Optional
Electrical connection	Open cable ends	MATE-N-LOK, 6-pin, male

Cable color-coding  
Pinout

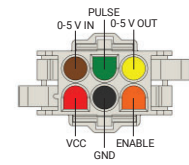
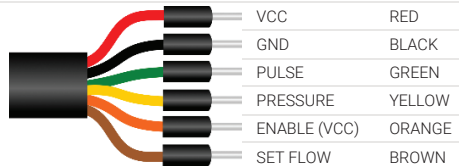

## PULSE channel GREEN

Channel assignment	Flow
Type	Open collector

PLC connection

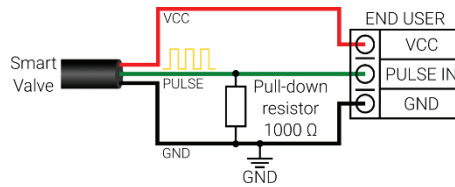

external 1000 Ω pull-down resistor required

Voltage level equal to VCC  
(voltage pull-up resistor)

Pulses/Liter	4000
--------------	------

## 0-5 V output channel YELLOW

Channel assignment	Pressure	
	<b>Standard</b>	<b>Optional</b>
Measurement range	0 – 1 bar	0 – 6 bar
Voltage range	$0 - 5 \text{ V } \text{meas.val.} = \frac{\text{max-min}}{5\text{V}} \cdot \text{meas.volt.}$	

## 0-5 V input channel BROWN

Channel assignment	Flow Rate Set Point
Set Point Range	0 – 3000 l/h
Voltage range	$0.5 - 4.5 \text{ V } \text{set.volt.} = 0.5 \text{ V} + \frac{4 \text{ V}}{3000 \text{ l/h}} \cdot \text{set.flow}$

## ENABLE signal ORANGE

Channel assignment	Enable (VCC voltage)
Description	Connect to VCC voltage to operate valve. Valve will remain always closed when enable signal is not connected to VCC voltage.

# Smart Valve

Pressure Independent Flow Control

## Dimensions

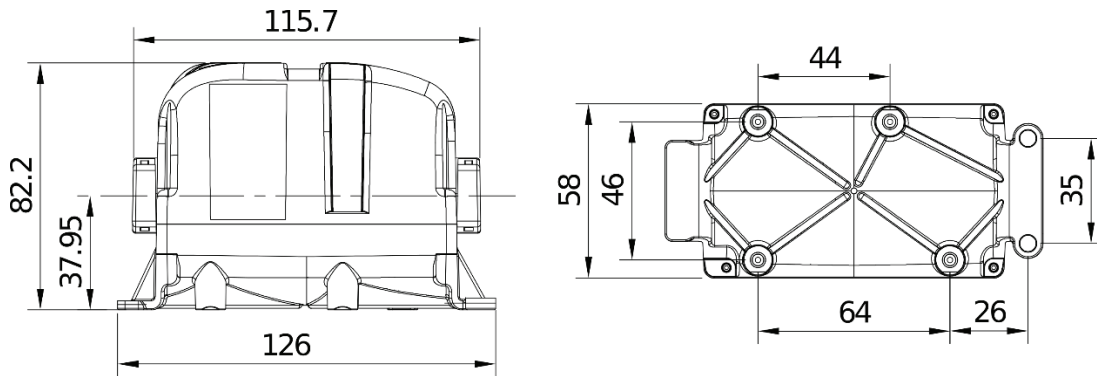

## Hydraulic Connection

### Hose Connection Adapters

Plastic DN12 Straight



Plastic DN15 Straight



Plastic DN12 90° Angled



### Thread Connection Adapters

Brass G 3/4" for flat seal

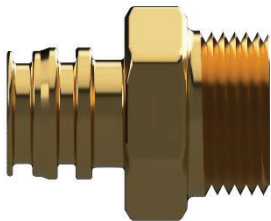

## Installation notes

### Orientation

Installable in any orientation. In vertical orientation, ensure adequate flow to prevent air bubble accumulation.

### Calming section

Ensure accurate readings with a calming section upstream and downstream of the sensor. Select the pipe ID according to the adapter dimensions.

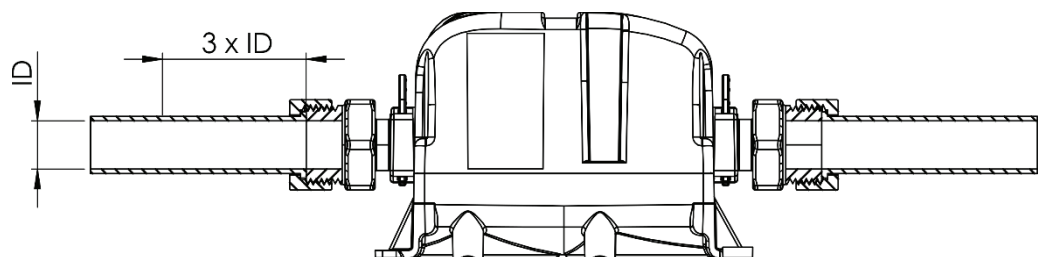



## About Us

Allengra GmbH, with headquarters in Germany and Romania, was established in 2005 and specializes in the design and production of standard or OEM ultrasonic flow sensors and control valves for liquids and gases, tailored to meet the specific needs of each end client application. Our company manages the entire development process, from concept to serial production, with various engineering departments and prototyping skills at our disposal.

Allengras core technology, ultrasonic metering, has been refined over the years to a level where both high-end device integration and cost-effective applications are achievable. Allengra provides metering and regulating solutions for various industries, including gas heating boilers, automatic coffee machines, robotic scrubbers, and industrial automation, among others.

## Über Uns

Die 2005 gegründete Allengra GmbH mit Sitz in Deutschland und Rumänien entwickelt und produziert sowohl Standard- als auch maßgeschneiderte Ultraschall-Durchflusssensoren und Regelventile für Flüssigkeiten und Gase. Allengra vereint alle notwendigen Engineering und Prototyping Fähigkeiten, um die Produkte interdisziplinär und ganzheitlich zu entwickeln. So können auch neue und innovative Ideen schnell und flexibel in robuste Serienprodukte überführt werden.

Allengras Kernkompetenz, die Ultraschall-Durchflussmessung, kann durch die umfangreiche und langjährige Erfahrung mit der Technologie problemlos sowohl in High-End-Produkte als auch in robuste und kostengünstige Serienlösungen integriert werden. Allengra bietet Mess- und Regelungslösungen für Anwendungen in Gasheizkesseln, Kaffeefullautomaten, Bodenreinigungsmaschinen, dem Motorsport, der industriellen Automatisierung und vieles mehr.